

Application Note No. 9261-001  
**Power and Signal Line Interruptions  
 for Automotive Tests**

**Electronic Switch TOE 9261**

9261E-AN001\_Rev01.doc

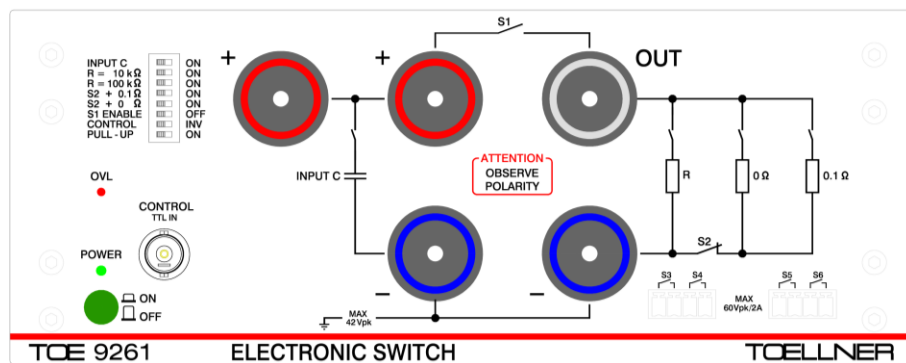

**TOELLNER®**

TOELLNER ELECTRONIC INSTRUMENTE GMBH  
 Gahlenfeldstrasse 31, 58313 Herdecke, Germany  
 ☎ +49 (0) 23 30 - 97 91 91 • Fax +49 (0) 23 30 - 97 91 97  
 E-Mail: [info@toellner.de](mailto:info@toellner.de) • Web: [www.toellner.de](http://www.toellner.de)

Subject to technical changes

<b>1.</b>	<b>Introduction .....</b>	<b>3</b>
1.1	Required test equipment .....	3
<b>2.</b>	<b>Tests according to standard LV 124.....</b>	<b>5</b>
2.1	LV 124, E-10, Short interruptions .....	5
2.2	E-10, Short interruptions – reference measurements .....	6
2.3	LV 124, Test E-13, Pin interruption .....	7
2.3.1	E-13, interruption of signal pins up to 4 A current.....	7
2.3.2	E-13, interruption of signal pins up to 4 A current – reference measurements .....	8
2.3.3	E-13, interruption of signal pins at currents > 4 A.....	9
2.3.4	E-13, interruption of signal pins at currents > 4 A – reference measurements .....	10
2.3.5	E-13, interruption of ground pins up to 4 A current .....	10
2.3.6	E-13, interruption of ground pins up to 4 A current – reference measurements .....	11
2.3.7	E-13, interruption of ground pins at currents > 4 A .....	12
2.3.8	E-13, interruption of ground pins at currents > 4 A – reference measurements .....	13
<b>3.</b>	<b>Tests according to standard LV 148.....</b>	<b>14</b>
3.1	LV 148, E48-09, Short interruptions .....	14
<b>4.</b>	<b>Tests according to standard VDA 320.....</b>	<b>15</b>
4.1	VDA 320, E48-09, Short interruptions .....	15
4.2	VDA 320, E48-09, Short interruptions – reference measurements.....	16

# 1. Introduction

The Electronic Switch **TOE 9261** is a device for time-based turning on and off of load and signal currents. This device provides an electronic, unidirectional power switch as well as four electronic bidirectional signal line switches. The power switch can be used for switching the positive supply line of the load as well as the negative return path (ground). In the configuration for switching the positive line, a selectable load-parallel crossover for selective discharging of buffered loads is provided.

A digital input signal can be used to generate on- and off-durations of any time down to the microsecond range for both the power switch and the signal line switches.

By these features, the TOE 9261 especially is applicable for the following tests according to the automotive standards LV 124, LV 148, and VDA 320:

- LV 124, E-10: Short interruptions
- LV 124, E-13: Pin interruption
- LV 148, E48-09: Short interruptions
- VDA 320, E48-09: Short interruptions

There are many other industry standards based on LV 124, LV 148, and VDA 320 like VW 80000, GS 95024-2, VW 82148, etc. with power and signal line interruptions, where the Electronic Switch TOE 9261 can be applied.

Subject of this document is how these tests are carried out by use of the TOE 9261, especially under consideration of the following points:

- Test assembly and wiring of the components
- Choice of the right switch, i.e. power switch resp. signal line switch of the TOE 9261
- Reference measurements according to the requirements of the LV 124-2013 or later
- Reference measurements according to the requirements of the VDA 320-2014 or later

## 1.1 Required test equipment

Commonly the following components are needed for the test assemblies:

- DUT (Device under Test)
- Power supply according to the requirements of the Device under Test
- Electronic Switch **TOE 9261**
- 4x high current cable (cross section 16 mm<sup>2</sup>) with connector KBT6AR-N/16-S (Manufacturer: Multi-Contact) to connect the power supply and the DUT to the power switch of the TOE 9261.

**Note** Please note, that the connector KBT6AR-N/16-S can only be mounted to a cable by use of special tooling, soldering is not possible.

The use of the following connection cables of length 1.20 m or 0.50 m TOE 9260/22 (Red) and TOE 9260/23 (Blue) is recommended:

Item No.	Item name
TOE 9260/22	0.50 m connection cable with 1 safety socket, red
TOE 9260/23	0.50 m connection cable with 1 safety socket, blue
TOE 9260/24	1.20 m connection cable with 1 safety socket, red
TOE 9260/25	1.20 m connection cable with 1 safety socket, blue

- Recommended: PC with Software **TOELLNER WaveControl** and DAQ-card for generation of the test pulse waveforms especially for the tests LV 124 E-10 resp. LV 148 / VDA 320 E48-09. A suitable DAQ-card from the National Instruments NI X series can be ordered via Toellner.  
Not recommended for new test setups is the use of the Arbitrary Function Generator TOE 7761 together with a PC and a control script file for pulse sequence generation. This constellation may not longer be fully supported in case of new test standards or updates to the existing test standards.
- Oscilloscope or fast data logger for evaluation of the measurement results

When performing tests according to LV 124-2013 or later, additionally:

- Reference resistors 1  $\Omega$ , 100  $\Omega$ , and 1 k $\Omega$  of low inductance,  $\pm 5\%$  tolerance to perform reference measurements. For use with the power switch, the following reference resistor kit is recommended:

Item No.	Item name
TOE 9260/100	Reference Resistor Kit 1 $\Omega$ , 100 $\Omega$ , and 1 k $\Omega$ for power switch

When performing tests according to VDA 320-2014 or later, additionally:

- Reference resistors 10  $\Omega$  and 1 k $\Omega$  of low inductance,  $\pm 5\%$  tolerance to perform reference measurements. For use with the power switch, the following reference resistor kit is recommended:

Item No.	Item name
TOE 9260/120	Reference Resistor Kit 10 $\Omega$ and 1 k $\Omega$ for power switch

Also a combined kit is available:

Item No.	Item name
TOE 9260/110	Reference Resistor Kit 1 $\Omega$ , 10 $\Omega$ , 100 $\Omega$ , and 1 k $\Omega$ for power switch

## 2. Tests according to standard LV 124

### 2.1 LV 124, E-10, Short interruptions

Test E-10 shall be applied to power supply lines of the DUT.

The test assembly for the test E-10 is shown in Fig. 1.

For test case 1 neither the DIP switch “S2 + 0 Ω” nor the DIP switch “S2 + 0.1 Ω” is set to the “ON” position.

For test case 2 the DIP switch “S2 + 0 Ω” must be switched “ON”.

For test case 3 of the 2009 version of the LV 124 standard the DIP switch “S2 + 0.1 Ω” must be “ON” and “S2 + 0 Ω” must be “OFF”.

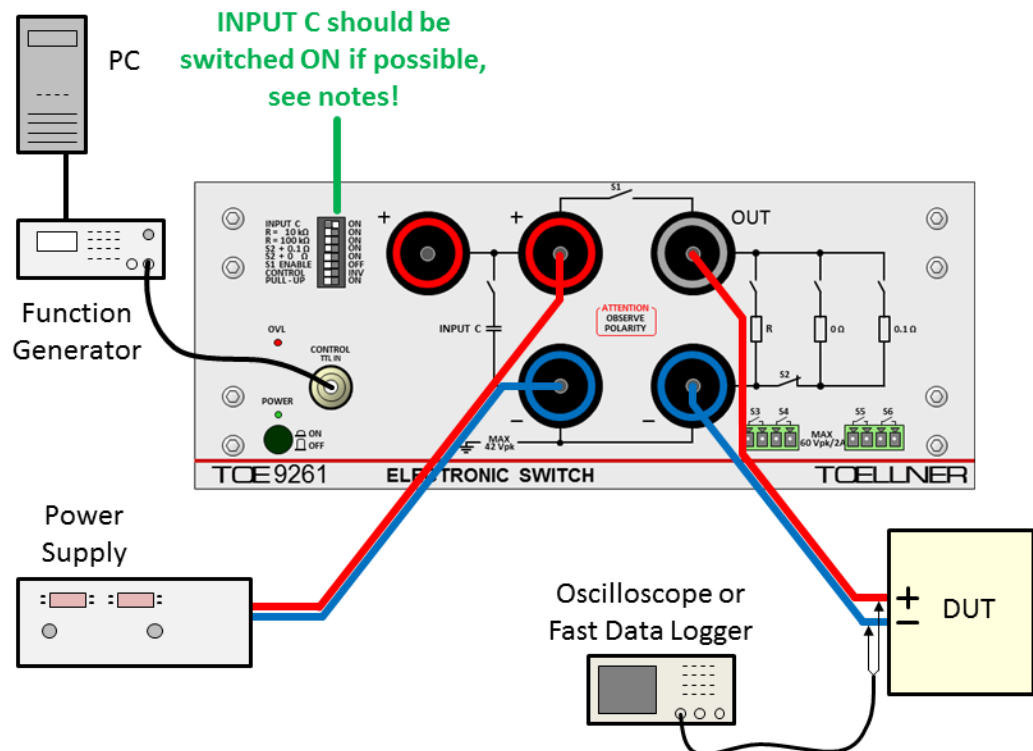

Fig. 1: Test assembly for LV 124, E-10

**Note** The important points for test execution in line with the requirements of the standard refer to the wiring:

- The cross section of the cables must fit to the drawn current. For currents up to 100 A please use the cables TOE 9260/22 and TOE 9260/23 (length 0.50 m) resp. TOE 9260/24 and TOE 9260/25 (length 1.20 m).
- The two wires from the power supply to the “Plus” and “Minus” sockets of the TOE 9261 have to be laid as closely spaced as possible (e.g. twisted) to reach minimum inductance values.
- As long as no artificial network is applied between the power supply and the “Plus” and “Minus” sockets of the TOE 9261, the internal capacitor at the input of the TOE 9261 should be activated by setting the DIP switch “INPUT C” to “ON”. So the shortest possible rise and fall times of the voltage at the DUT are achieved.

- If an artificial network between the power supply and the “Plus” and “Minus” sockets of the TOE 9261 is necessary, the internal capacitor at the input of the TOE 9261 must be deactivated by setting the DIP switch “INPUT C” to “OFF”. In that case the two wires from the artificial network to the “Plus” and “Minus” sockets of the TOE 9261 have to be laid as closely spaced as possible (e.g. twisted) and also kept as short as possible to get short rise and fall times at the DUT.
- Also the two wires from the “OUT” and “Minus” sockets of the TOE 9261 to the DUT have to be laid as closely spaced as possible (e.g. twisted) and shall be kept as short as possible. Any additional cable inductance will act as an inductive filter together with the resistance and / or capacitance of the DUT, which results in increased rise and fall times measured at the DUT.
- If the DUT has to be connected by a wiring harness or if a wiring harness is part of the DUT, the said remarks are valid for the cables from the “OUT” and “Minus” sockets of the TOE 9261 to the start point of the wiring harness.

## 2.2

### E-10, Short interruptions – reference measurements

This section applies to LV 124, version 2013 or later only. Reference measurements are required before an interruption test is carried out with the DUT. Such a reference measurement gives proof of the slew rate of the switching operation. For the reference measurements of the E-10 test the DUT is replaced by a reference resistor of  $1 \Omega \pm 5 \%$  resp.  $100 \Omega \pm 5 \%$  of low parasitic inductance (→ Fig. 1).

To avoid the addition of cable inductivity, the reference resistor shall be connected as close to the “OUT” and “Minus” sockets of the TOE 9261 as possible. The reference resistors of the kits **TOE 9260/100...120** are connected directly to the sockets without use of cables.

Because of the high power loss in case of the  $1 \Omega$  resistor operated at 11 V according to the LV 124, the test setup should be prepared in the powerless state. Test execution should be kept as short as possible.

## 2.3 LV 124, Test E-13, Pin interruption

The test E-13 has to be applied to signal pins as well as to ground pins. The choice of the applicable switch of the TOE 9261 is made in relation to the pin current. For the different situations, the test assemblies are explained in the following.

**Note** To get short rise and fall times at the DUT, in general all loop areas of the wiring shall be kept as small as possible and the wires shall be kept as short as possible.

### 2.3.1 E-13, interruption of signal pins up to 4 A current

For the interruption of a signal pin, a signal line switch of the TOE 9261 is used. Such a signal line switch is applicable for a pin current up to 2 A.

If up to 4 A have to be switched, two signal line switches can be paralleled. It is not recommended to operate more than two switches in parallel. With three or four switches in parallel the timing requirements of the LV 124-2013 cannot be fulfilled with a 1 k $\Omega$  reference resistor anymore. (For applications different from the LV 124 / LV 148 standards, there are four signal line switches available in the TOE 9261; if e.g. differential pairs or a 4-pole connection shall be switched at once.)

Fig. 2 shows the test assembly with use of one or two parallel signal line switches of the TOE 9261. Only one pin has to be interrupted at one time. The test is then sequentially carried out for every signal pin of the DUT.

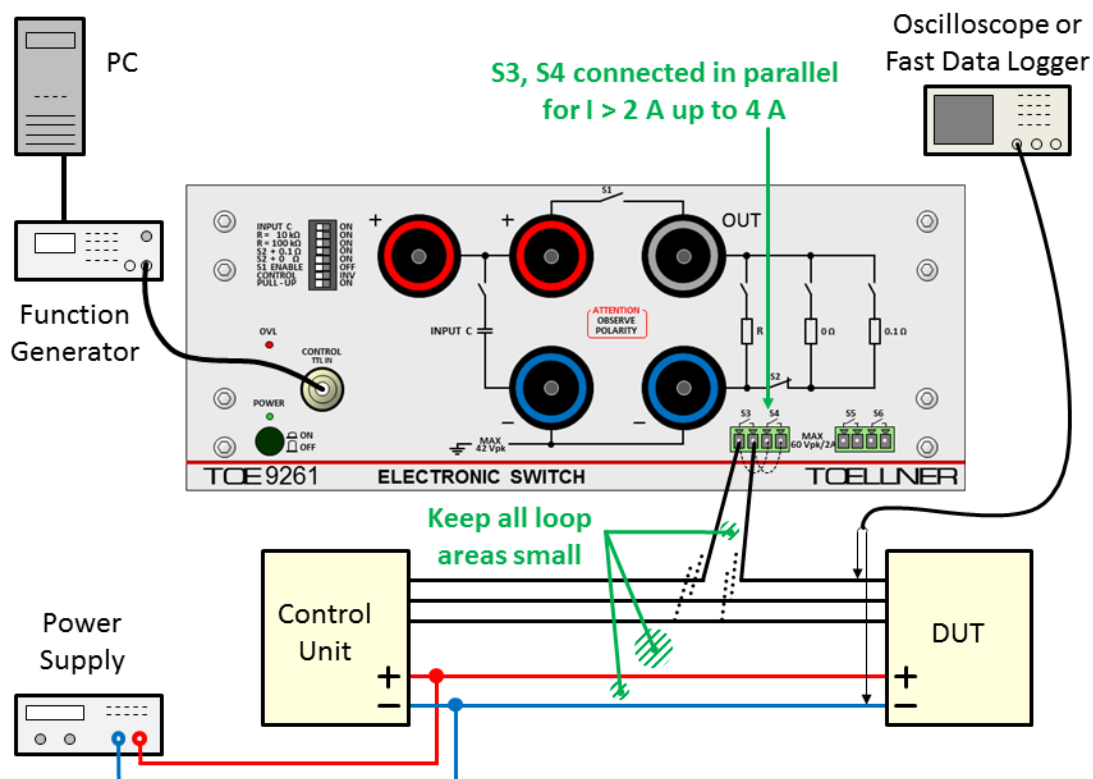

Fig. 2: Test assembly for LV 124, E-13; interruption of a signal pin up to 4 A

### 2.3.2

### E-13, interruption of signal pins up to 4 A current – reference measurements

This section applies to LV 124, version 2013 or later only. Reference measurements are required before an interruption test is carried out with the DUT. Such a reference measurement gives proof of the slew rate of the switching operation. For the reference measurements of the E-13 test the DUT is replaced by a reference resistor of  $1\ \Omega \pm 5\%$  /  $4\ \text{W}$  resp.  $1\ \text{k}\Omega \pm 5\%$  of low parasitic inductance each. The reference resistor is connected instead of the switched pin and the “minus” pin of the DUT ( $\rightarrow$  Fig. 2).

To avoid the addition of too high cable inductivity, the reference resistor shall be connected close to the signal line switch by closely spaced wires.

Due to the 2 A current limit of a signal line switch, the measurement with the  $1\ \Omega$  resistor must be carried out at a limited voltage of 2 V as shown in Fig. 3. Applying such a reduced voltage level instead of the actual voltage of the signal pin of the control unit has no significant influence on the timing of the measured waveform. Reference measurements with the  $1\ \text{k}\Omega$  resistor can be executed with the same voltage as the regular voltage level of the respective pin of the DUT.

If the DUT is tested with two paralleled signal line switches ( $\rightarrow$  2.3.1), the reference measurements have to be carried out with the same configuration of paralleled switches. Even then the test voltage for the  $1\ \Omega$  resistor should not exceed 2 V, because the power dissipation of the resistor amounts to 4 W already.

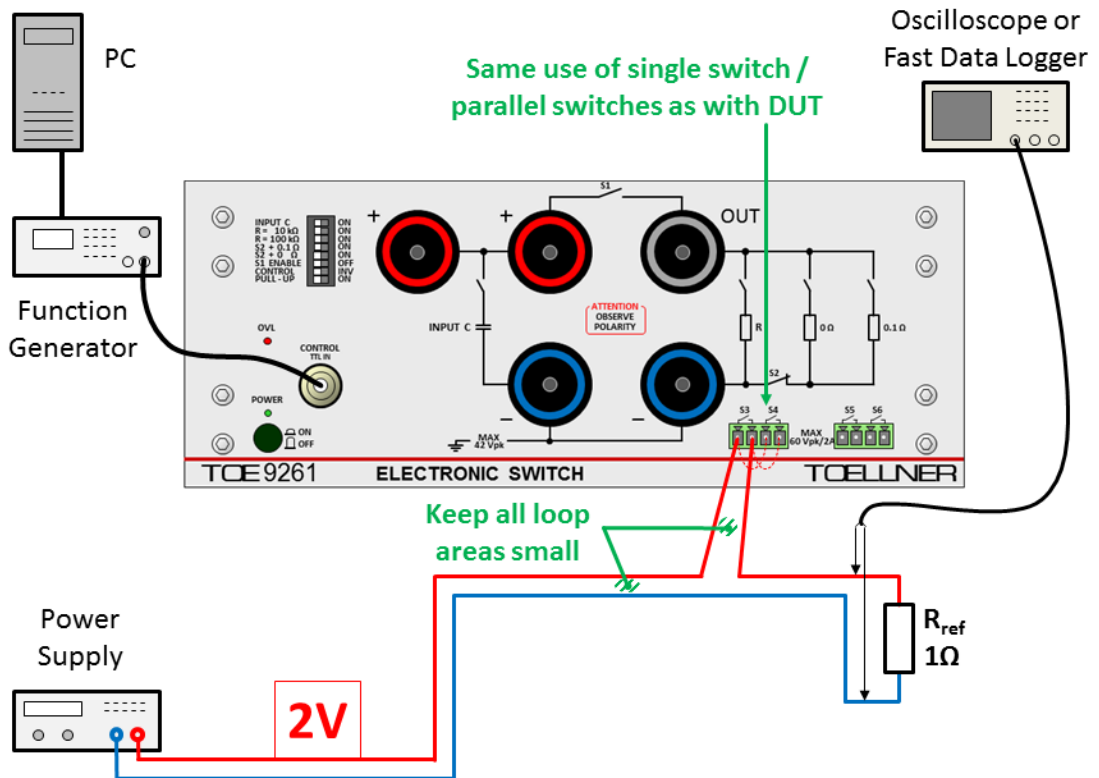

Fig. 3: Measurement with a 1 Ω reference resistor at a voltage level of 2 V



### 2.3.3

#### E-13, interruption of signal pins at currents > 4 A

For the interruption of a signal pin at a higher current than 4 A, the power switch of the TOE 9261 must be applied. The test assembly is shown in Fig. 4. Because the power switch is a unidirectional switch only, attention must be paid to the direction of current flow. Usually, the current will be sourced by the control unit and sunken by the DUT. If, the other way round, the DUT sources the current, DUT and control unit must be interchanged.

The DIP switch "INPUT C" must be in the left position, i.e. switched off, so that no capacitive load is added to the signal line. Also both the DIP switches "S2 + 0.1 Ω" and "S2 + 0 Ω" have to be at the left positions (off), because no discharge of the signal line shall take place during the interruption.

Only one pin has to be interrupted at one time. The test is then sequentially carried out for every signal pin of the DUT.

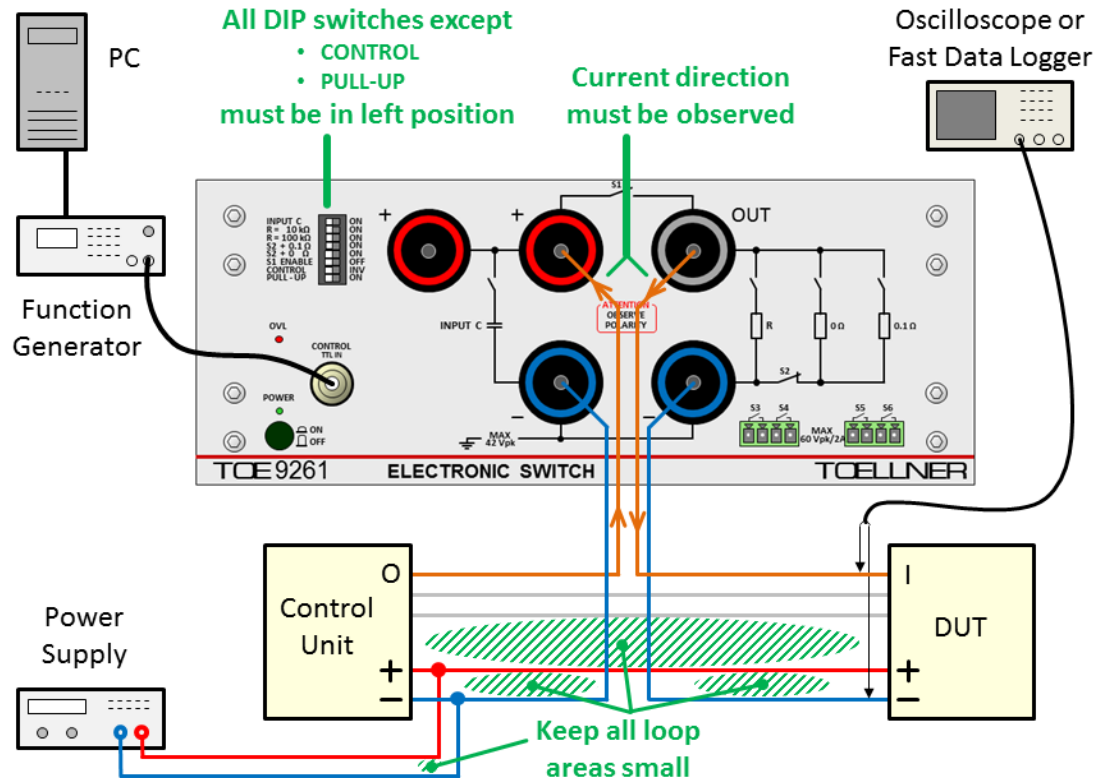

Fig. 4: Test assembly for LV 124, E-13; interruption of a signal pin > 4 A

**Note** The important points for test execution in line with the requirements of the standard refer to the wiring:

- The cross section of the cables must fit to the drawn current. For currents up to 100 A please use the cables TOE 9260/22 and TOE 9260/23 (length 0.50 m) resp. TOE 9260/24 and TOE 9260/25 (length 1.20 m).
- The two wires from the control unit to the "Plus" and "Minus" sockets of the TOE 9261 have to be laid as closely spaced as possible (e.g. twisted) and shall be kept as short as possible to reach minimum inductance values.
- Also the two wires from the "OUT" and "Minus" sockets of the TOE 9261 to the DUT have to be laid as closely spaced as possible (e.g. twisted) and shall be kept as short as possible. Any additional cable inductance will act as an inductive filter together with the resistance and / or capacitance of the DUT, which results in increased rise and fall times measured at the DUT.
- If the DUT has to be connected by a wiring harness or if a wiring harness is part of the DUT, the said remarks are valid for the cables from the "OUT" and "Minus" sockets of the TOE 9261 to the start point of the wiring harness.
- The positive supply wire has to be laid closely spaced to the negative (ground) wires.

2.3.4

**E-13, interruption of signal pins at currents > 4 A – reference measurements**

This section applies to LV 124, version 2013 or later only. Reference measurements are required before an interruption test is carried out with the DUT. Such a reference measurement gives proof of the slew rate of the switching operation. For the reference measurements of the E-13 test the DUT is replaced by a reference resistor of  $1 \Omega \pm 5 \%$  resp.  $1 \text{ k}\Omega \pm 5 \%$  of low parasitic inductance each. The reference resistor is connected instead of the switched pin and the “minus” pin of the DUT ( $\rightarrow$  Fig. 4).

To avoid the addition of cable inductivity, the reference resistor shall be connected as close to the “OUT” and “Minus” sockets of the TOE 9261 as possible. The reference resistors of the kits **TOE 9260/100...120** are connected directly to the sockets without use of cables.

Because of the high power loss in case of the  $1 \Omega$  resistor operated at e.g. 12 V, the test setup should be prepared in the powerless state. Test execution should be kept as short as possible.

2.3.5

**E-13, interruption of ground pins up to 4 A current**

Also for the interruption of a ground pin, a signal line switch of the TOE 9261 is used. Such a signal line switch is applicable for a ground current up to 2 A.

If up to 4 A have to be switched, two signal line switches can be paralleled. It is not recommended to operate more than two switches in parallel. With three or four switches in parallel the timing requirements of the LV 124-2013 cannot be fulfilled with a  $1 \text{ k}\Omega$  reference resistor anymore.

Fig. 5 shows the test assembly with use of one or two parallel signal line switches of the TOE 9261.

To get short rise and fall times at the DUT, all loop areas of the wiring shall be kept as small as possible and the wires shall be kept as short as possible.

**Note** If the applied power supply has an internal capacitance between its minus terminal and earth, the oscilloscope resp. data logger must not earth the minus terminal of the reference resistor. Otherwise a capacitance appears across the signal line switch, and the switching times increase, especially at small load currents.  
A differential probe or an isolating transformer for supplying the oscilloscope resp. data logger shall be used in this case.

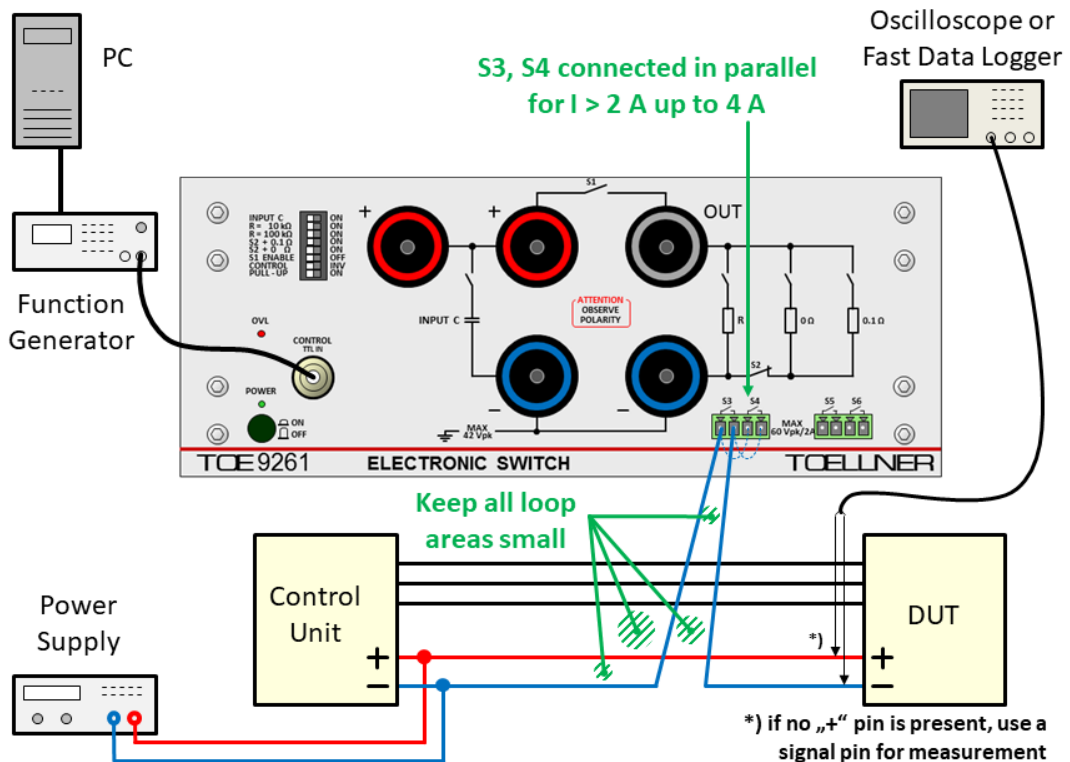

Fig. 5: Test assembly for LV 124, E-13; interruption of a ground pin up to 4 A

## 2.3.6

### E-13, interruption of ground pins up to 4 A current – reference measurements

This section applies to LV 124, version 2013 or later only. Reference measurements are required before an interruption test is carried out with the DUT. Such a reference measurement gives proof of the slew rate of the switching operation. For the reference measurements of the E-13 test the DUT is replaced by a reference resistor of  $1\ \Omega \pm 5\%$  resp.  $1\ \text{k}\Omega \pm 5\%$  of low parasitic inductance each. The reference resistor is connected instead of the “plus” pin (or, if no “plus” pin is present, a signal pin) and the switched “minus” pin of the DUT (→ Fig. 5).

To avoid the addition of too high cable inductivity, the reference resistor shall be connected close to the signal line switch by closely spaced wires.

Due to the 2 A current limit of a signal line switch, the measurement with the  $1\ \Omega$  resistor must be carried out at a limited voltage of 2 V as shown in Fig. 6. Applying such a reduced voltage level instead of the actual voltage of the control unit has no significant influence on the timing of the measured waveform. Reference measurements with the  $1\ \text{k}\Omega$  resistor can be executed with the same voltage as the regular DUT operation voltage.

If the DUT is tested with two paralleled signal line switches (→ 2.3.5), the reference measurements have to be carried out with the same configuration of paralleled switches. Even then the test voltage for the  $1\ \Omega$  resistor should not exceed 2 V, because the power dissipation of the resistor amounts to 4 W already.

**Note** If the applied power supply has an internal capacitance between its minus terminal and earth, the oscilloscope resp. data logger must not earth the minus terminal of the reference resistor. Otherwise a capacitance appears across the signal line switch, and the switching times increase, especially at the small load current in case of the  $1\ \text{k}\Omega$  reference resistor.

A differential probe or an isolating transformer for supplying the oscilloscope resp. data logger shall be used in this case.

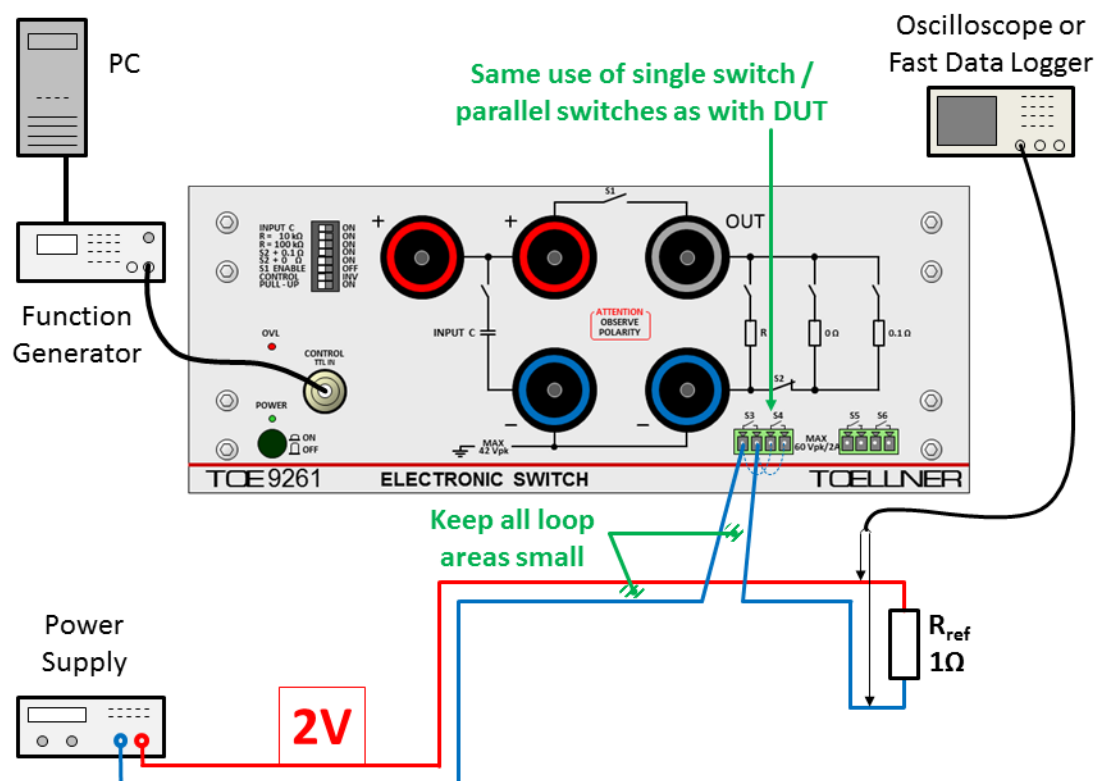

Fig. 6: Measurement with a  $1\ \Omega$  reference resistor at a voltage level of 2 V

### 2.3.7

#### E-13, interruption of ground pins at currents > 4 A

For the interruption of a ground pin at a higher current than 4 A, the power switch of the TOE 9261 must be applied. The test assembly is shown in Fig. 7.

If the DUT has only control and ground pins but no positive supply pin, one of the control lines can be fed via the TOE 9261 in place of the positive supply line for proper operation.

For all DUTs the setup of the TOE 9261 shall be the following:

The DIP switch “INPUT C” shall be in the left position, i.e. switched off, so that no capacitive load is added to a possible signal line.

To apply the power switch for ground interruptions, the current is switched by S2 instead of S1. Therefore the following settings are required:

The DIP switch “S2 + 0 Ω” has to be switched “ON” (right position).

The DIP Switch “S1 ENABLE” has to be switched “OFF” (right position, too).

As S2 is driven inversely to S1, it may be advantageous to set the DIP switch “CONTROL” to “INV”. For details please refer to the TOE 9261 manual.

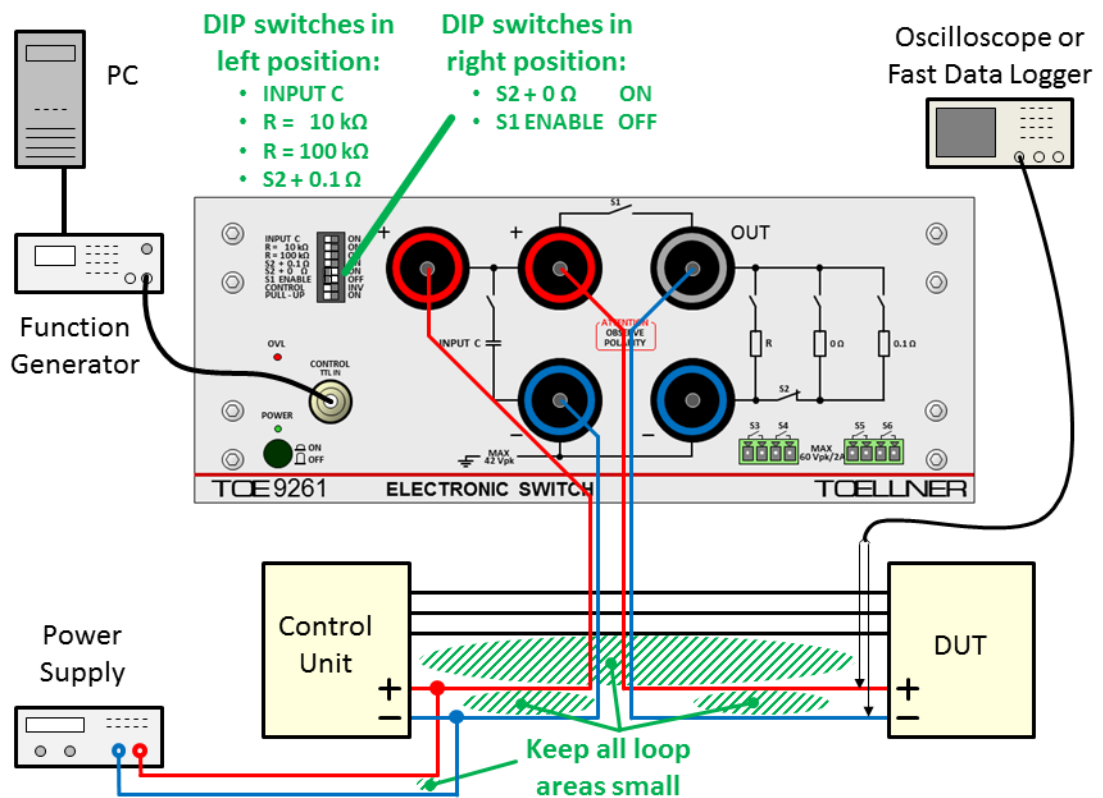

Fig. 7: Test assembly for LV 124, E-13; interruption of a ground pin > 4 A

**Note** The important points for test execution in line with the requirements of the standard refer to the wiring:

- The cross section of the cables must fit to the drawn current. For currents up to 100 A please use the cables TOE 9260/22 and TOE 9260/23 (length 0.50 m) resp. TOE 9260/24 and TOE 9260/25 (length 1.20 m).
- The two wires from the control unit to the “Plus” and “Minus” sockets of the TOE 9261 have to be laid as closely spaced as possible (e.g. twisted) and shall be kept as short as possible to reach minimum inductance values.
- Also the two wires from the “Plus” and “OUT” sockets of the TOE 9261 to the DUT have to be laid as closely spaced as possible (e.g. twisted) and shall be kept as short as possible. Any additional cable inductance will act as an inductive filter together with the resistance and / or capacitance of the DUT, which results in increased rise and fall times measured at the DUT.

- If the DUT has to be connected by a wiring harness or if a wiring harness is part of the DUT, the said remarks are valid for the cables from the “Plus” and “OUT” sockets of the TOE 9261 to the start point of the wiring harness.
- Signal line wires have to be laid closely spaced to the negative (ground) wires.

### 2.3.8

#### E-13, interruption of ground pins at currents > 4 A – reference measurements

This section applies to LV 124, version 2013 or later only. Reference measurements are required before an interruption test is carried out with the DUT. Such a reference measurement gives proof of the slew rate of the switching operation. For the reference measurements of the E-13 test the DUT is replaced by a reference resistor of  $1\ \Omega \pm 5\ %$  resp.  $1\ \text{k}\Omega \pm 5\ %$  of low parasitic inductance each, which is connected to the sockets “Plus” and “OUT” of the TOE 9261 in this case (→ Fig. 7). To avoid the addition of cable inductivity, the reference resistor shall be connected as close to these sockets as possible. The reference resistors of the kits **TOE 9260/100...120** are connected directly to the sockets without use of cables.

Because of the high power dissipation in case of the  $1\ \Omega$  resistor operated at e.g. 12 V, the test setup should be prepared in the powerless state. Test execution should be kept as short as possible.

### 3. Tests according to standard LV 148

#### 3.1 LV 148, E48-09, Short interruptions

Fig. 8 shows the test assembly for test E48-09. According to the LV 148 standard the DIP switch “S2 + 0 Ω” has to be set to the “ON” position.

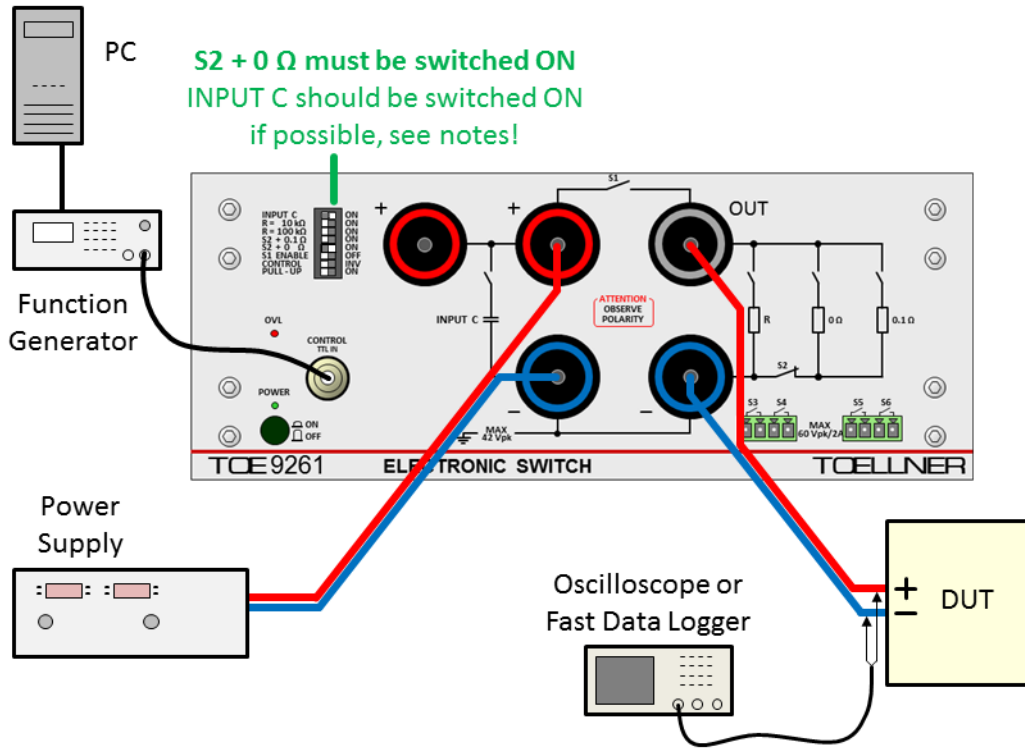

Fig. 8: Test assembly for LV 148, E48-09

**Note** The important points for test execution in line with the requirements of the standard refer to the wiring:

- The cross section of the cables must fit to the drawn current. For currents up to 100 A please use the cables TOE 9260/22 and TOE 9260/23 (length 0.50 m) resp. TOE 9260/24 and TOE 9260/25 (length 1.20 m).
- The two wires from the power supply to the “Plus” and “Minus” sockets of the TOE 9261 have to be laid as closely spaced as possible (e.g. twisted) to reach minimum inductance values.
- As long as no artificial network is applied between the power supply and the “Plus” and “Minus” sockets of the TOE 9261, the internal capacitor at the input of the TOE 9261 should be activated by setting the DIP switch “INPUT C” to “ON”. So the shortest possible rise and fall times of the voltage at the DUT are achieved.
- If an artificial network between the power supply and the “Plus” and “Minus” sockets of the TOE 9261 is necessary, the internal capacitor at the input of the TOE 9261 must be deactivated by setting the DIP switch “INPUT C” to “OFF”. In that case the two wires from the artificial network to the IN sockets of the TOE 9261 have to be laid as closely spaced as possible (e.g. twisted) and also kept as short as possible to get short rise and fall times at the DUT.
- Also the two wires from the “OUT” and “Minus” sockets of the TOE 9261 to the DUT have to be laid as closely spaced as possible (e.g. twisted) and shall be kept as short as possible. Any additional cable inductance will act as an inductive filter together with the resistance and / or capacitance of the DUT, which results in increased rise and fall times measured at the DUT.
- If the DUT has to be connected by a wiring harness or if a wiring harness is part of the DUT, the said remarks are valid for the cables from the OUT sockets of the TOE 9261 to the start point of the wiring harness.



## 4. Tests according to standard VDA 320

### 4.1 VDA 320, E48-09, Short interruptions

Fig. 9 shows the test assembly for test E48-09. According to the VDA 320 standard the DIP switch "S2 + 0  $\Omega$ " has to be set to the "ON" position.

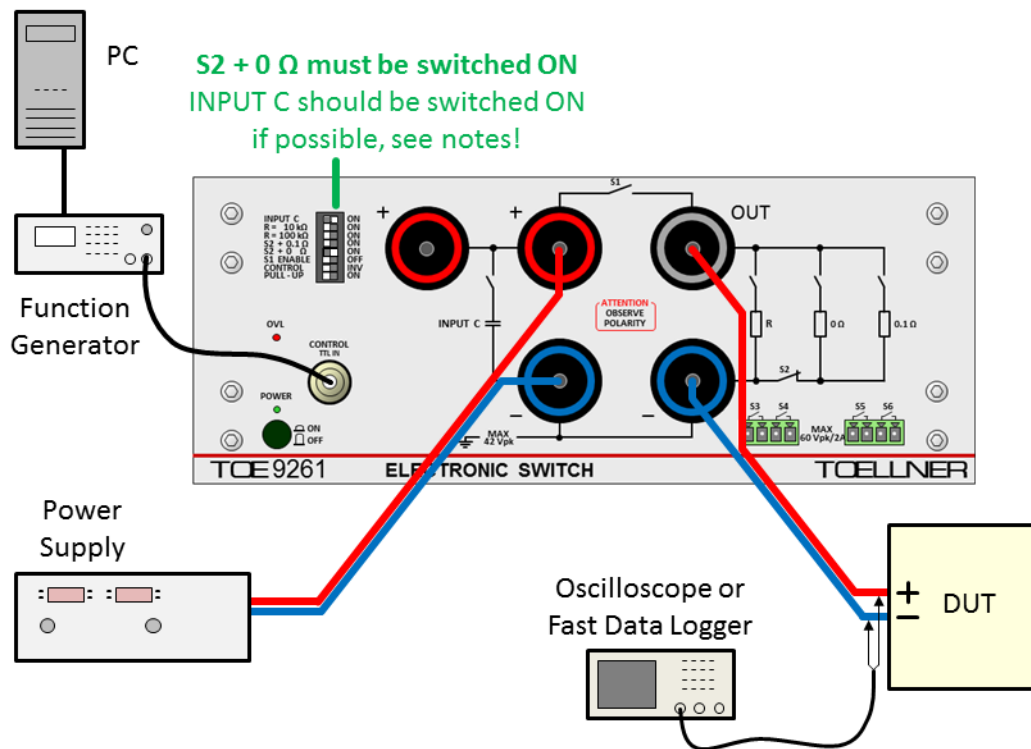

Fig. 9: Test assembly for VDA 320, E48-09

- Note** | The important points for test execution in line with the requirements of the standard refer to the wiring:
- The cross section of the cables must fit to the drawn current. For currents up to 100 A please use the cables TOE 9260/22 and TOE 9260/23 (length 0.50 m) resp. TOE 9260/24 and TOE 9260/25 (length 1.20 m).
  - The two wires from the power supply to the "Plus" and "Minus" sockets of the TOE 9261 have to be laid as closely spaced as possible (e.g. twisted) to reach minimum inductance values.
  - As long as no artificial network is applied between the power supply and the "Plus" and "Minus" sockets of the TOE 9261, the internal capacitor at the input of the TOE 9261 should be activated by setting the DIP switch "INPUT C" to "ON". So the shortest possible rise and fall times of the voltage at the DUT are achieved.
  - If an artificial network between the power supply and the "Plus" and "Minus" sockets of the TOE 9261 is necessary, the internal capacitor at the input of the TOE 9261 must be deactivated by setting the DIP switch "INPUT C" to "OFF". In that case the two wires from the artificial network to the IN sockets of the TOE 9261 have to be laid as closely spaced as possible (e.g. twisted) and also kept as short as possible to get short rise and fall times at the DUT.
  - Also the two wires from the "OUT" and "Minus" sockets of the TOE 9261 to the DUT have to be laid as closely spaced as possible (e.g. twisted) and shall be kept as short as possible. Any additional cable inductance will act as an inductive filter together with the resistance and / or capacitance of the DUT, which results in increased rise and fall times measured at the DUT.
  - If the DUT has to be connected by a wiring harness or if a wiring harness is part of the DUT, the said remarks are valid for the cables from the OUT sockets of the TOE 9261 to the start point of the wiring harness.

## 4.2

### VDA 320, E48-09, Short interruptions – reference measurements

This section applies to VDA 320, version 2014 or later only. Reference measurements are required before an interruption test is carried out with the DUT. Such a reference measurement gives proof of the slew rate of the switching operation. For the reference measurements of the E48-09 test the DUT is replaced by a reference resistor of  $10\ \Omega \pm 5\ %$  resp.  $1\ \text{k}\Omega \pm 5\ %$  of low parasitic inductance (→ Fig. 9).

To avoid the addition of cable inductivity, the reference resistor shall be connected as close to the “OUT” and “Minus” sockets of the TOE 9261 as possible. The reference resistors of the kits **TOE 9260/100...120** are connected directly to the sockets without use of cables.

Because of the high power dissipation in case of the  $10\ \Omega$  resistor operated at 48 V according to the VDA 320, the test setup should be prepared in the powerless state. Test execution should be kept as short as possible.